

User's Manual

For FD430

Digital 2-Phase Stepper Driver

All Rights Reserved, No reproduction

[Attention: Please read this manual carefully before using the drive!]

Changzhou Fulling Motor Co, Ltd

Add: No.69 KunLun Road, New District, Changzhou City, 213032, China

Tel: +86-519-85132957

Fax: +86-519-85132956

Web site: www.fullingmotor.com

Email: info@fullingmotor.com

Contents

I .Product introduction	3
1. Overview	3
2. Features.....	3
3. Applictaiions	3
II .Electrical, Meachanical, Environment Specifications	3
1. Electrical Specifications	3
2. Operating Environment and Other Parameters	3
3. Mechanical Installation Dimensions Diagram.....	4
4. Elimination of Heat.....	4
III.Driver Interface and Wiring Introductio n.....	4
1. Interface Description	4
2. Control Signal Interface Circuit.....	5
3. Sequence Chart of Control Signals.....	5
4. Control Signal Mode Setting	6
5. Wiring Require.....	6
IV.Selecting Microstep Resolution , Driver Output Current and Parameter auto-tuning	6
1.Current Settings	6
2.Microstep Resolution Selection.....	6
3.Parameter atuo-tuning function	7
V.Power Supply Selection	7
VI.Motor Option	7
1.Motor option.....	7
2.Motor Wiring	7
2) Set value of output curren.....	8
VII.Typical Connection	8
VIII.Protection Functions	9
IX.Frequently Asked Questions	9
1. Problem Symptoms and Possible Causes	10
2. Drive FAQ	10
Product warranty terms	10

FD430

Digital 2-Phase Stepper Driver

I . Introduction, Features and Applications

1. Introduction

The FD430 is the company's new digital stepping driver based on the latest 32-bit ARM digital processing technology, Drive control algorithm uses advanced variable current technology and advanced frequency conversion technology. The driven motors can run with low heating, small noise, smooth movement. Thanks to the built-in micro-resolution technology, the effect of high resolution can be achieved and the driven motors can run with much smaller noise, lower heating, smoother movement at low to high speed even under low resolution conditions. Motor auto-identification and parameter auto-configuration technology offers optimum responses with different motors and easy-to-use.

2. Features

- New 32-bit DSP Technology
- Ultra-low vibration noise
- Built-in high resolution
- pulse frequency up to 500 KHz(default 160KHz)
- Motor auto-identification and parameter auto-configuration technology.
- Output current programmable, from 0.1A to 3A
- Variable current control for less motor heating
- Micro-step resolutions programmable range, from 200 to 51200 steps/rev
- Automatic idle-current reduction in half.
- Over-voltage, Under-voltage, over-current protections
- Suitable for 4,6,8 lead 2-phase motors
- Optically isolated input signals,

3. Applications

It can be used in various kinds of small and medium-sized equipment and machines, such as engraving machines, labeling machines, laser cutters, laser typesetting, plotting instrument, CNC machine, automatic assembly equipment, and so on. Particularly adapt to the applications desired with low noise, high speed.

II .Electrical, Mechanical, Environment Specifications

1. Electrical Specifications

Parameters	FD430			
	Min	Typical	Max	Unit
Output Current	0.1	-	3.0	A
Input Voltage	12	24	32	VDC
Logic Signal Current	6	10	16	mA
Logic Signal Voltage	4.5	5	28	Vdc
Minimum Pulse Width of logic signal	1.5	-	-	us
Pulse input frequency	0	-	160	KHz
Isolation resistance	500			MΩ

2. Operating Environment and other Parameters

Cooling		Natural Cooling or Forced cooling
Operating Environment	Environment	Don't place next to other heating equipment, Avoid dust, oil fog and corrosive gases, excessive humidity and strong vibration, No flammable gas and conductive dust.
	Ambient Temperature	-5°C ~ +50°C (23°F ~ 122°F)
	Humidity	40 ~ 90%RH
	Vibration	5.9m/s ² MAX
Storage Temperature		-20°C ~ 80°C (-4°F ~ 176°F)
Altitude		Below 1000 meters

Weight	Approx. 0.090 Kg
--------	------------------

3. Mechanical Dimensions (unit: mm, 1 inch = 25.4 mm)

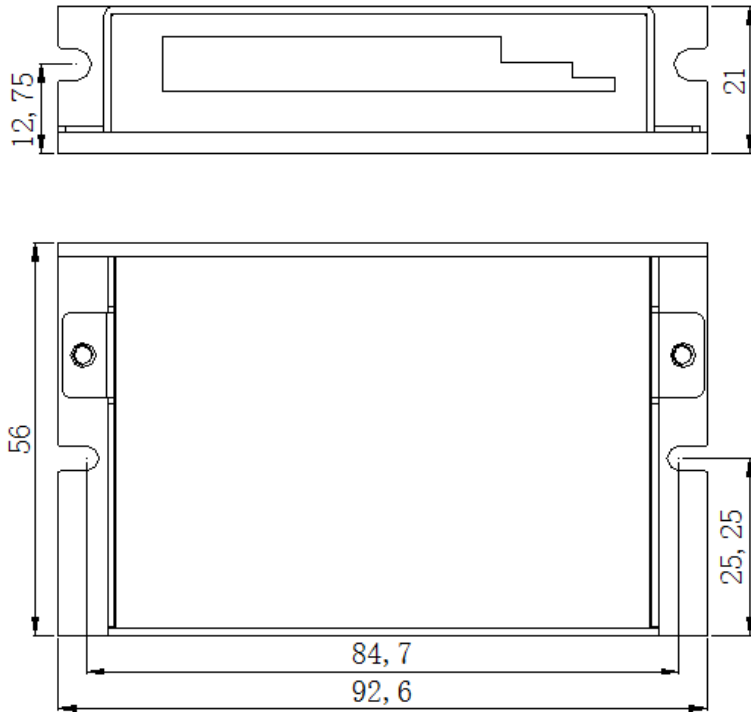

Figure 1: Mechanical dimensions

*Recommended to use side mounting for better heat dissipation, When designing the installation size, pay attention to the terminal size and wiring.

4. Elimination of Heat

- 1) Driver's reliable working temperature should be $<60^{\circ}\text{C}$, and motor working temperature should be $<80^{\circ}\text{C}$ (176°F);
- 2) It is recommended to use automatic idle-current mode, namely current automatically reduce to 50% when motor stops, so as to reduce driver heating and motor heating;
- 3) It is recommended to mount the driver vertically to maximize heat sink area. Use forced cooling method to cool the system if necessary, Ensure that the drives operation in a reliable operating temperature range.

III. Pin Assignment and Description

1. Interface description

1) Control Signal Connector

Signal	Functions Details
PUL+	Pulse signal: This input represents pulse signal, each rising edge active, 4.5~28Vdc when PUL-HIGH, 0~0.5V when PUL-LOW, For reliable response, pulse width should be longer than 1.5 μs .
PUL-	
DIR+	Direction signal: this signal has low/high voltage levels, representing two directions of motor rotation; For reliable motion response, DIR signal should be ahead of PUL signal by 2 μs at least. 4.5V-28Vdc when DIR-HIGH, 0-0.5V when DIR-LOW. Please note that rotation direction is also related to motor-driver wiring match. Exchanging the connection of two wires for a coil to the driver will reverse motion direction.
DIR-	
ENA+	Enable signal: This signal is used for enabling/disabling the driver. High level for enabling the driver and low level for disabling the driver. When ENA-HIGH is connected to 4.5V-28Vdc, ENA-LOW is connected to 0-0.5V (or Internal optical coupling is conducted), the driver will cut off the current of each phase of the motor to make the motor in a free state, step pulses are not responded at this time. Usually left unconnected (enabled) .
ENA-	

2) Power Connector Configurations

Signal	Functions Details
GND	Power Ground.
+Vdc	power supply, +12V~ +32Vdc Including voltage fluctuation and EMF voltage, Recommended 24Vdc supply.
A+, A-	Motor coil A (leads A+ and A-)
B+, B-	Motor coil B (leads B+ and B-)

3) RS232/RS485 Communication Port

Special RS232 cable (Prohibition of charging plug) designed to setup communication between the drive and PC-based configuration & tuning software ProTuner. The PC software is used to configure the peak current, microstep, active level, current loop parameters and the driver function, and so on.

Pin	Symbol	Name	Description
1	+5V	+5V power output	For external STU only
2	TxD	RS232 transmit	

3	RxD	RS232 receive	
4	GND	Ground	0V
5	NC		

Notice: The FD430 RS232 cable must be a special cable, which is provided according to the user's situation, Please confirm the cable before use to avoid damage.

4) LED Status Indicator

The green LED is Power indicator light, The LED turns on when the driver is powered on and functions normally. When driver is powered off, the LED is off. The FD430 uses one RED LED to indicate what protection has been activated. The red LED blinks periodically (in every 3 seconds) to indicate the error type. When the fault is cleared by the user, the red LED is always off. The specific relationship is shown in the following table.

Number	Time(s) of Blink	Sequence wave of Red LED	Description
1	1		Over current protection or Single short circuit between two phases
2	2		Over Voltage protection
3	3		No definition
4	4		No definition

2. Control Signal Connector Interface

This FD430 driver uses differential inputs to increase noise immunity and interface flexibility. Single-ended (common-cathode or common-anode) control signals from the controller can also be accepted by this interface. The input circuit has built-in high-speed opto-coupler, and can accept signals in the format of line driver, open-collector, or PNP output. Recommend use line driver control signals to increase noise immunity of the driver in interference environments.

In the following figures, connections to open-collector and PNP signals are illustrated.

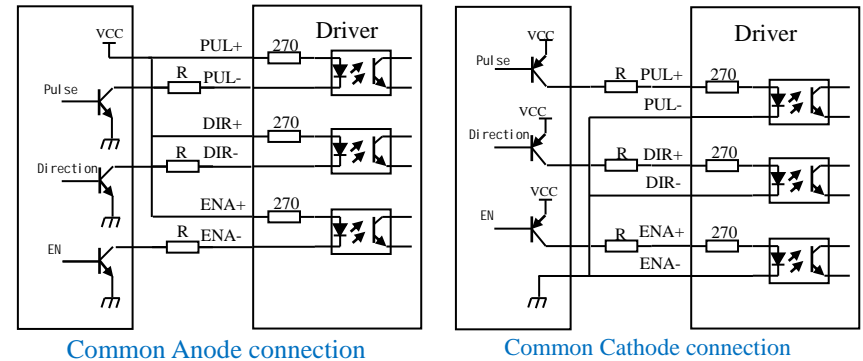

Figure 3: Input interface Circuit

Note: When VCC is 4.5V~28Vdc, R is connected or not.

3. Sequence Chart of Control Signals

In order to avoid some fault operations and deviations, PUL, DIR and ENA should abide by some rules, shown as following diagram:

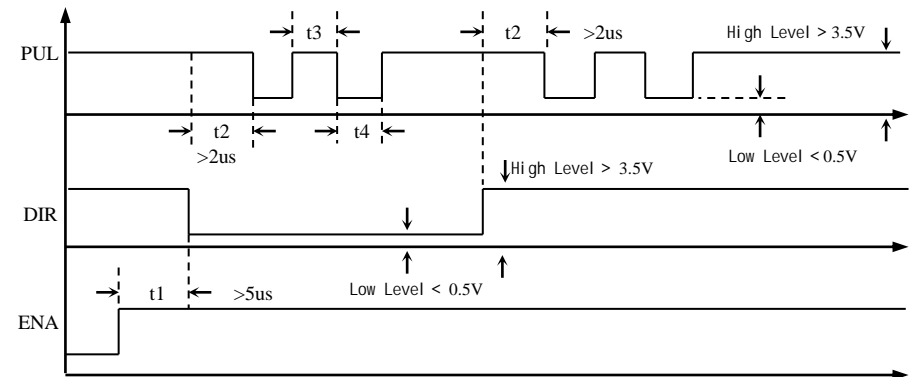

Figure 4 Sequence chart of control signals

Note:

- 1) **t1: ENA must be ahead of DIR by at least 5us. Determined high level. Usually, ENA+ and ENA- are NC (not connected).**
- 2) **t2: DIR must be ahead of PUL active edge by 2ms to ensure correct direction;**
- 3) **t3: Pulse width not less than 2s;**
- 4) **t4: Low level width not less than 2us.**

4. Control Signal Mode Setting

Pulse trigger edge and single/double pulse selection: By PC software (ProTuner software) or STU debugger set the rising or falling edge trigger of the pulse is a valid, and set single or double pulse mode. In the double-pulse mode, the signal at the direction control terminal must be kept high or left floating.

5. Wire Connection

- 1) In order to improve anti-interference performance of the driver, it is recommended to use twisted pair shield cable, and the shield is shorted to ground, Except for special requirements, the shielded wire of the control signal cable is also shorted to single-ended ground. The upper end of the shielded wire is grounded, and the driver end is floating. Only allowed on the same point grounding in the same machine, If it is not a real ground wire, the interference may be serious, and the shielding layer is not connected at the time.
- 2) To prevent noise incurred in PUL/DIR signal, pulse/direction signal wires and motor wires should not be tied up together. It is better to separate them by at least 10 cm, otherwise the disturbing signals generated by motor will easily disturb pulse direction signals, causing motor position error, system instability and other failures.
- 3) If a power supply several drivers, parallel connection is recommend instead of daisy-chaining.
- 4) It is prohibited to pull and plug power connector P2 while the driver is powered ON, because there is high current flowing through motor coils (even when motor is at standstill). Pulling or plugging power connector P2 with power on will cause extremely high back-EMF voltage surge, which may damage the driver.
- 5) It is strictly forbidden to add lead to the terminal after adding tin, otherwise the terminal may be damaged due to the increased contact resistance.
- 6) Lug must not be exposed outside the terminal to prevent accidental short circuit and damage to the driver.

IV. Driver Current Output, Selecting Microstep Resolution and Parameter auto-tuning function

This FD430 driver uses an 8-bit DIP switch to set microstep resolution, motor dynamic current, standstill half-current, motor parameters and internal adjustment parameters auto-tuning, as shown below:

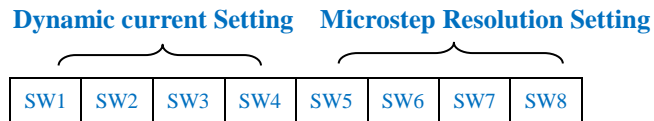

1. Current Setting

1) Dynamic current Setting

RMS Current	SW1	SW2	SW3	SW4
0.1A	on	on	on	on
0.2A	off	on	on	on
0.3A	on	off	on	on
0.5A	off	off	on	on
0.6A	on	on	off	on
0.7A	off	on	off	on
0.8A	on	off	off	on
1.0A	off	off	off	on
1.2A	on	on	on	off
1.3A	off	on	on	off
1.5A	on	off	on	off
1.6A	off	off	on	off
1.7A	on	on	off	off
1.8A	off	on	off	off
2.0A	on	off	off	off
2.2A	off	off	off	off

2) Standstill Current Setting

The standstill current can be defaulted to automatic half current.

2. Microstep Resolution Selection

Steps/rev	SW5	SW6	SW7	SW8	Resolution Description
Default[200]	on	on	on	on	When SW5,SW6,SW7 and SW8 are on, the driver uses the default number of resolution within the driver. Use PC ProTuner software or STU debugger to set the number of resolutions, the minimum value is 1, the resolution is 1, and the maximum value is 51200.
400	off	on	on	on	
800	on	off	on	on	
1600	off	off	on	on	
3200	on	on	off	on	
3600	off	on	off	on	
6400	on	off	off	on	
12800	off	off	off	on	
1000	on	on	on	off	
2000	off	on	on	off	
4000	on	off	on	off	
5000	off	off	on	off	
7200	on	on	off	off	
8000	off	on	off	off	
10000	on	off	off	off	
20000	off	off	off	off	

3. Parameter auto-tuning function

When the driver is an open-loop step, each parameter of the motor can be automatically identified once at each instant of powered-on, and the driver can automatically complete the auto-tuning of the motor parameters and internal adjustment parameters. To get the optimized performance, please repower the driver will auto-identify the new motor and auto-configure related control parameters when the motor power supply voltage and other conditions change.

Note that: pulse can't be input, the direction signal should not be changed, and the enable signal can't be connected at this time.

V. Power Supply Selection

It is important to choose appropriate power supply to make the driver operate properly and deliver optimal performance. Both unregulated and regulated power supplies can be used to supply DC power to the FD430 driver. If regulated power supply is indeed used, voltage ripple peak value after rectification doesn't exceed its specified maximum voltage. Therefore, it is suggested to use power supplies with theoretical output voltage of no more than its defined voltage, leaving room for power line fluctuation.

If regulated power supplies (such as most switching supplies.) are indeed used, it is important to have large current output rating to avoid problems like current clamp.

Please Note:

- 1) Power Supply polarity not then reversed.
- 2) Best to use an unregulated power supply.
- 3) If unregulated supply is used, The power supply current output capacity should be greater than 60% of the driver setting current.
- 4) If regulated supply is used, the average current withdrawn from power supply is more than or equal to driver current.
- 5) It is recommended to have two or three drives to share one power supply to reduce cost, if the supply has enough capacity.

VI. Motor option

The FD430 can drive any 2-phase and 4-phase of 4, 6, 8-lead hybrid stepping motors, which is suitable for 1.8° and 0.9° step angle motor. When selecting a motor, it is mainly

determined by the torque and rated current of the motor. The torque is determined by the size of the motor, the larger the size of the motor, the larger the torque.

While the current is mainly related to the inductance, the small-inductance motor has good high-speed performance, but larger currents.

1. Motor Option

1) Determine load torque, transmission ratio and working speed range.

$$T_{\text{motor}} = C (J\varepsilon + T_{\text{load}})$$

J: Moment of inertia of load

ε : Maximum angular acceleration of the load

C: Safety factor, recommend 1.2~1.4

T_{load} : Maximum load torque, Contains resistance torque such as payload, friction, transmission efficiency.

2) What factors determine the motor output torque

- For a given stepping motor and coil connection, the output torque has the following characteristics.
- For a given motor, higher driver current will make the motor to output more torque, but at the same time causes more copper loss heating in the motor and driver.
- Higher supply voltage can increase motor torque at higher speeds, thus helpful for avoiding losing steps.
- From the torque-frequency characteristic diagram of the stepper motor, the High-speed torque is smaller than that of the medium-low speed.

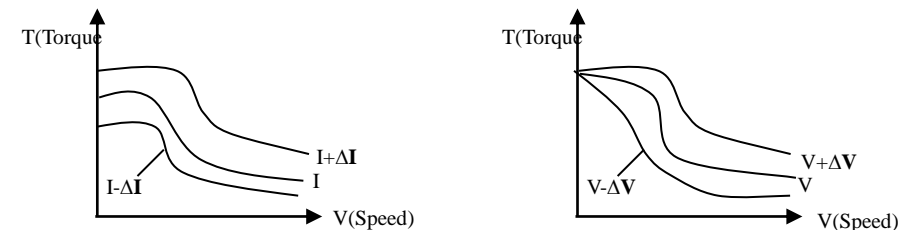

Figure 5 T/F Characteristic diagram

2. Connecting the Motor

For 6, 8 lead step motors, there are considerable differences in motor performance for different coil connections.

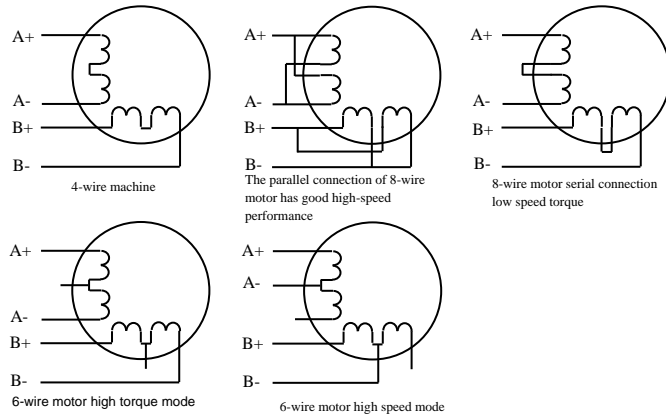

Figure 6 Motor Wiring

3. Power supply Selection, Driver Voltage and Current Selection

1) Power Supply Selection

Generally Speaking, Higher supply voltage can increase motor torque at higher speeds, thus helpful for avoiding losing steps. However, higher voltage may cause bigger motor vibration at lower speed, and it may also cause over-voltage protection or even driver damage.

2) Set Value of output current

For a given motor, higher driver current will make the motor to output more torque, but at the same time causes more heating in the motor and driver. Therefore, output current is generally set to be such that the motor will not overheat for long time operation. Phase current rating supplied by motor manufacturer is important to selecting driver current, but the selection also depends on leads and connection. In principle, If the temperature (<math><40^{\circ}\text{C}</math>) is very low, you can appropriately increase the current setting value to increase the motor output power as required(Torque and high-speed response).

- 4-lead motor: the output current is set to be equal to or less than the rated current of the motor.
- 6-lead motor high torque Mode: the motors should also be run at only 50% of their rated current which is unipolar connection.
- 6-lead motor high speed Mode: the motors should also be run at only 100% of their rated current which is unipolar connection.

- 8-lead motor Series Connections: the motors should also be run at only 70% of their rated current which is unipolar connection.
- 8-lead motor Parallel Connections: the motors should also be run at only 140% of their rated current which is unipolar connection.

[Note: After the current setting, please run the motor for 15~30 minutes, if the temperature rise of the motor is too high (>70°C), reduce the current setting value. Therefore, the general situation is to set the current to the value when the motor is warm for a long time, but it is not too hot.

VII. Typical Connection

The FD430 driver with SC42-08 motor which may be connected in series or parallel, If the motor direction is different from the expected direction, just exchange A+ and A-. FD430 driver can drive any 2-phase or 4-phase of 4, 6, 8- lead hybrid step motors. The following diagrams illustrate connection to various kinds of motor leads:

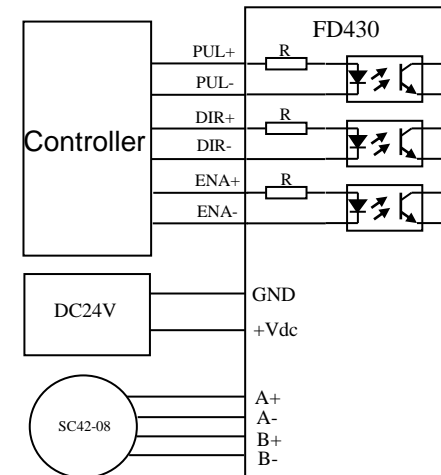

Figure 7 Typical Connection

Note:

- 1) Different motors have different phase wire colors. When using the motor, the motor data description shall be prevail, For example, the color of 57 and 86 motor wires is different.
- 2) The phase is relative, but the windings of different phases cannot be connected to the

terminals of the same phase of the driver(A+,A- is one phase, B+,B- is another phase). 57HS22 motor lead definition, Series and Parallel Connections method is shown below.

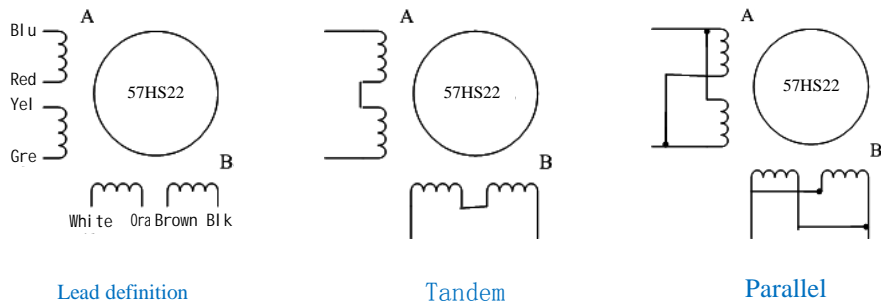

Figure8 Tandem and Parallel connection

- 3) FD430 driver can only drive 2-phase hybrid step motors, which cannot drive 3-phase and 5-phase stepping motor.
- 4) The method of judging whether the stepping motor is connected in series or in parallel is correct, When the driver is not connected, directly rotate the motor shaft by hand, If it can rotate easily and evenly, then the wiring method is correct; If the resistance is large and uneven rotation with a certain sound, then the wiring method is incorrect.

VIII. Protection Functions

1) Short Circuit Protection / Over-current Protection

Over-current protection will be activated when continuous current exceeds the limit current value or in case of short circuit between motor coils or between motor coil and ground, and RED LED will turn on once within each periodic time (3 s). Reset the driver by repowering it to make it function properly after removing above problems.

2) Over-voltage protection

When power supply voltage exceeds 38VDC, protection will be activated and RED LED will turn on twice within each periodic time (3 s). Reset the driver by repowering it to make it function properly after removing above problems.

3) Phase Error Protection

Motor power lines wrong & not connected will activate this protection. RED LED will turn on four times within each periodic time (3 s). Reset the driver by repowering it to make it function properly after removing above problems.

Attention: since there is no protection against power leads (+, -) reversal, it is critical

to make sure that power supply leads correctly connected to driver. Otherwise, the driver will be damaged instantly.

IX. Frequently Asked Questions

1. Problem Symptoms and Possible Causes

Symptoms	Possible Problems	Solution
Motor is not rotating	No Power	Check the power supply circuit for normal power supply
	The motor shaft strong, Control signal is too weak.	Control pulse signal is too weak, Signal current increased to 7~16mA
	microstep resolution is too small	select the right microstep resolution setting
	Current setting is too small	Select the right current setting
	Drive is protected.	Power on again
	Enable signal is low high.	Enable signal is high or not connected.
Motor rotating in the wrong direction	Does not respond to Input control signals	Not powered.
	Motor phases may be connected in reverse	Exchanging the connection of two wires for a coil to the driver will reverse motion direction.
Alarm indicator is on	Wrong motor connection	Check connection
	Power supply is too high or too low.	Check Power Supply
	Motor or Driver is bad.	Replace motor or driver
Inaccurate location	Control signal is disturbed	Eliminate interference
	Shielded ground is not connected or disconnect	Reliable grounding.
	Open winding of motor	Check motor wire
	Micro-step resolution setting is wrong.	select the right micro-step resolution setting

	Current setting is too small, losing steps	Choose another power supply with larger power or increase the output current of drive.
Motor stalls during acceleration	Acceleration is set too high	Reduce the acceleration
	Motor is undersized for the application	Choose another motor with higher torque
	Power supply voltage too low or Current setting is too small.	Choose another power supply with larger power or increase the output current of drive

2. Drive Frequently Asked Questions

1) What are Stepper Motor and Stepper Driver?

A stepper motor is a particular type of DC motor that can achieve very precise positioning and/or speed control. When a discrete DC voltage is applied, the stepper motor rotates in a particular angle called the step angle. Therefore calls Stepping motor which is characterized by no cumulative error. Receive each a pulse of electric from controller, the motor is driven at a fixed angle by the driver, So it is widely used in various open loop control.

The stepping driver is a power amplifier that enables the stepping motor to run, It can convert the pulse signal from the controller into the power signal of the stepping motor. The speed of the motor is proportional to the pulse frequency, So the control pulse frequency can be adjusted precisely speed, the number of control pulses can be accurately positioned.

2) What is the drive resolution? What is the relationship between the speed of the stepping motor and the pulse frequency?

Because of its unique structure, the stepping motor is marked with the inherent step angle when it leaves the factor. The step angle such as 0.9 degree/1.8 degree, it means that the angle turned by each step of the half-step work is 0.9 degree, and the full-step is 1.8 degree. However, in many precision control situations, the angle of the entire step is too large, which affects the control accuracy and the vibration is too large. Therefore, it is required to complete a motor's inherent step angle via in many subdivision steps. This is the so-called subdivision drive, the electronic device capable of this function is called a micro-step resolution driver.

$$V = \frac{P * \theta_e}{360 * m}$$

V: Motor Speed(r/s)

P: Pulse frequency(Hz)

θe: Motor inherent step angle

m: Number of subdivisions(1 for full-step, 2 for half-step)

3) What are the benefits of subdivision driver?

- Reduce the step angle of each step, improve the step uniformity, so the control accuracy can be improved.
- The method can make the rotor run smoothly, so this method can be considered as one of the effective methods to reduce vibration at low speed.
- Can effectively reduce torque ripple and increase output torque.

4) Why does my motor only turn in one direction?

- The direction signal may be too weak, or the wiring polarity is wrong, or the signal voltage is too high which lead to burn-out direction current limiting resistor.
- The pulse mode does not match, The signal is in the pulse/direction, So the driver must be set to this mode. If the signal is CW/CCW(double pulse mode), the driver must also be in this mode, otherwise the motor will only run in one direction.

Product warranty terms

1 Twelve Month Limited Warranty

Changzhou Fulling Motor Co, Ltd. Warranty its products against defects in materials and workmanship for a period of 12 months from shipment out of factory. During the warranty period, Fulling Motor will either, at its option, repair or replace products which proved to be defective.

2 Exclusions

The above warranty does not extend to any product damaged by reasons of improper or inadequate handlings by customer, improper or inadequate customer wiring, unauthorized modification or misuse, or operation beyond the electrical specifications of the product and/or operation beyond environmental specifications for the product. And poor ambient heat dissipation.

3 Obtaining Warranty Service

If your product fail during the warranty period, need to obtain a returned material authorization number before returning product for service. Please include a written description of the problem along with contact name and address.

4 Warranty Limitations

- The warranty coverage of the product is limited to the device and process (i.e. consistency)
- Fullingmotor specifically disclaims the implied warranties of merchantability and fitness for a particular purpose. Because the suitability is also related to the technical indicators of the use and the conditions of the use and environment.