

iST57-FD Series

Integrated Open-loop Stepper Motor User Manual

Versions: V1.0

All the Copyrights cannot be reprinted
[Please read this manual carefully before use to avoid damaging the driver]



Contents

| | |
|---|----|
| 1. Product introduction..... | 3 |
| 1.1. Introduction..... | 3 |
| 1.2. Characteristics..... | 3 |
| 1.3. Application Fields..... | 4 |
| 2. Electrical, Mechanical and Environmental Indicators..... | 4 |
| 2.1. Electrical specifications..... | 4 |
| 2.2. Use environment and parameters..... | 4 |
| 2.3. Mechanical structure dimension diagram..... | 5 |
| 2.4. Heat dissipation precautions..... | 6 |
| 3. Driver interface definition and wiring introduction..... | 6 |
| 3.1. Interface Description..... | 6 |
| 3.2. Control signal interface circuit..... | 7 |
| 3.3. Control signal timing diagram..... | 9 |
| 3.4. Dip switch Settings..... | 10 |
| 3.5. LED Status Indication..... | 10 |
| 3.6. Wiring requirements..... | 11 |
| 4. Common problems and solutions..... | 12 |
| 5. Product warranty clause of FULLING MOTOR..... | 12 |



iST57-FD

Integrated Open-loop Stepper Motor

1. Product introduction

1.1. Introduction

The iST57-FD integrated open-loop stepper motor adopts a 32-bit ARM digital processor, with built-in smooth micro subdivision and intermediate frequency vibration suppression technology, which has the advantages of smooth operation, ultra silence, high torque, and low heat generation. The fine division and phase current can be set through dialing, and the interface definition is simple and convenient to use.

1.2. Characteristics

- Adopting a 32-bit motor control dedicated chip
- Open loop vector control technology
- Low speed ultra quiet, smooth current, suitable for various scenarios
- Voltage level 12VDC~48VDC, supporting wide voltage input
- Pulse signal level supports TTL 3.3V \ 5V, and supports common cathode and common anode connection methods
- Control command maximum pulse frequency 250KHz
- It has protection functions such as overvoltage, undervoltage, overcurrent, and overheating
- Built in smooth micro subdivision technology
- When the motor is stationary, the current automatically decays to reduce heat generation
- Ultra high cost-effectiveness, cost-effective and efficient
- Acceptable customization

1.3. Application Fields

Widely used in various small and medium-sized automation equipment, instruments, and motion mechanisms, such as electronic processing equipment, 3C non-standard automation equipment, screw locking machines, wire stripping machines, winding machines, terminal machines, laser machines, marking machines, spray painting machines, small and medium-sized carving machines, automatic grabbing equipment, specialized CNC machine tools, packaging equipment and industrial robots, service robots, etc.

2. Electrical, Mechanical and Environmental Indicators

2.1. Electrical specifications

| Parameter | Index | | | |
|---------------------------|---------------|---------------|---------------|------|
| | Minimum value | Typical value | Maximum value | Unit |
| Power supply voltage | 10 | 24 | 50 | Vdc |
| Continuous output current | 2 | - | 5 | A |
| Logic input voltage | 3.3 | 5 | 5.5 | Vdc |
| Output logic voltage | - | - | 50 | Vdc |
| Output logic current | 0 | 50 | 80 | mA |
| Command pulse frequency | 0 | - | 250 | kHz |

2.2. Use environment and parameters

| Parameters | Index |
|-------------|------------------------------|
| Temperature | -20°C ~ 50°C |
| Humidity | 40 ~ 90%RH (No condensation) |
| Vibration | < 55Hz / 0.15mm |

| | |
|---------------------|--|
| On site environment | Avoid approaching other heat sources, avoid dust, oil mist, corrosive gases, places with high humidity and strong vibrations, and prohibit the presence of combustible gases and conductive dust |
| Storage temperature | -20°C ~ 65°C |
| Type of cooling | Natural cooling or forced air cooling |

2.3. Mechanical structure dimension diagram

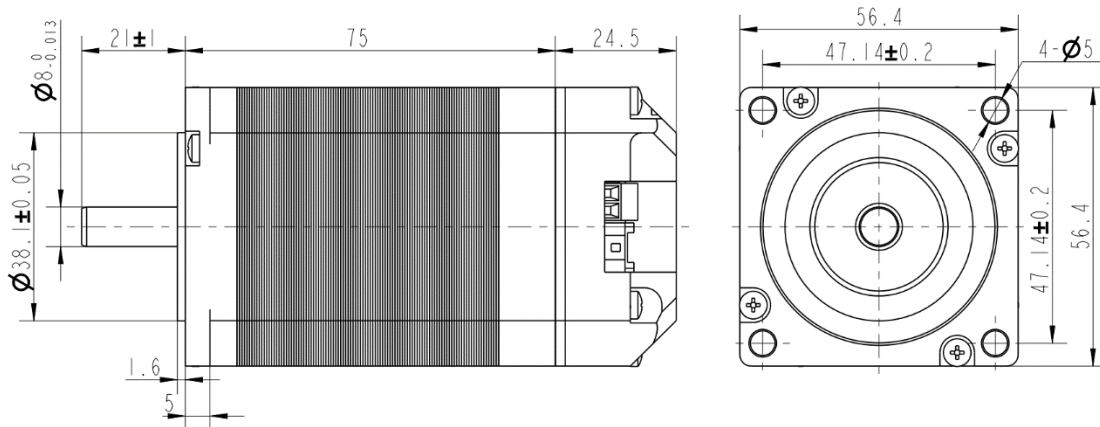

FIG. 1 Mechanical dimensions

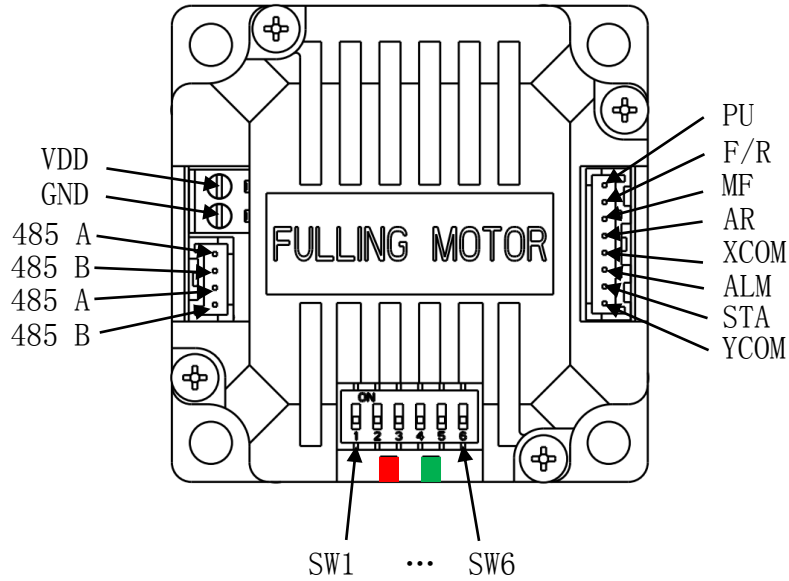

FIG. 2 Terminal definition diagram

2.4. Heat dissipation precautions

The reliable working temperature of an integrated open-loop stepper motor is usually within 80 °C. When installing, please use an upright side installation to create strong air convection on the surface of the radiator. If necessary, install a fan near the driver to force heat dissipation and ensure that the driver operates within a reliable working temperature range.

3. Driver interface definition and wiring introduction

3.1. Interface Description

3.1.1 Control Port (B08B-PASK-1 (LF) (SN) 8-bit Pin)

| Pin number | Signal | Function | Explanation |
|------------|--------|-----------|---|
| 1 | PU | pulse | Supports 3.3V and 5V levels, using higher levels requires external current limiting resistors |
| 2 | F/R | direction | Conduction refers to forward rotation, and cutoff refers to reverse rotation |



| | | | |
|---|------|-------------------------------|---|
| 3 | MF | Enable | Conduction is enabled, cutoff is stopped |
| 4 | AR | Alarm clear | Conduction can clear fault signals |
| 5 | XCOM | Input signal common terminal | Supports common anode and common cathode wiring |
| 6 | ALM | Alarm output | OC gate output |
| 7 | STA | Motor operating status | High level normal, low level alarm |
| 8 | YCOM | Output signal common terminal | OC gate output |

3.1.2 Power Port (DB125-3.5-2P 2-bit pin)

| Pin number | Signal | Function Description |
|------------|--------|--|
| 1 | VDD | Power input positive terminal, input voltage 10V~50Vdc |
| 2 | GND | Power input negative terminal |

3.2. Control signal interface circuit

The input signal interface of the iST57-FD driver is a single ended signal input, supporting common cathode and common anode connection methods, and is equipped with a high-speed optoelectronic isolation coupler.

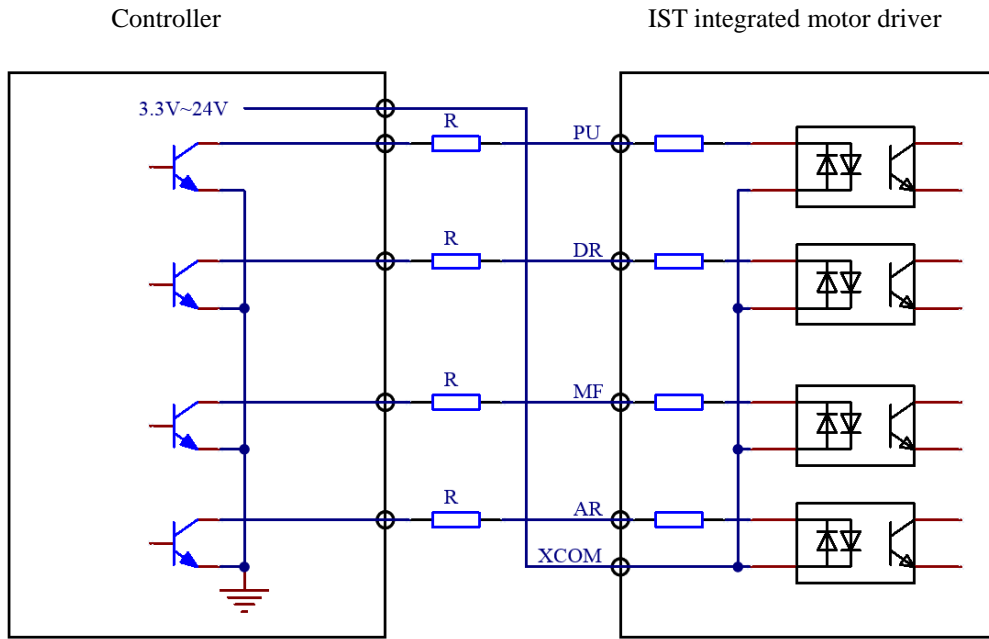

FIG. 3 Input signal common anode connection method

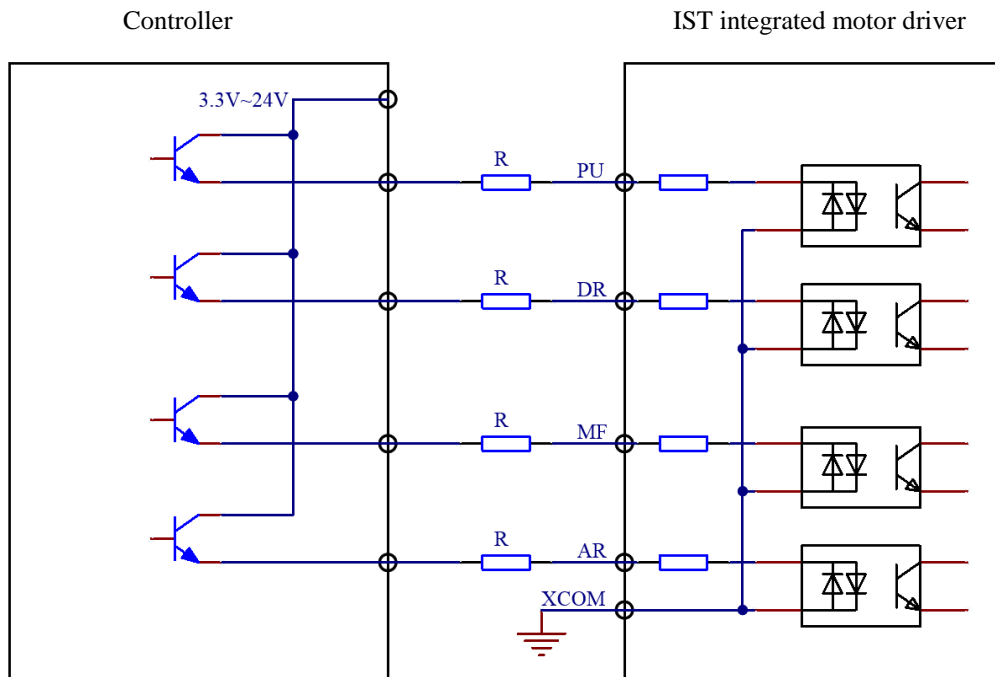

FIG. 4 Input signal common cathode connection method

Selection of resistance value for current limiting resistor R:

| Controller signal output level | Recommended resistance value |
|--------------------------------|------------------------------|
| +3.3\5V | 0Ω |
| +12V | 680Ω,1/4W |
| +24V | 1200Ω,1/4W |

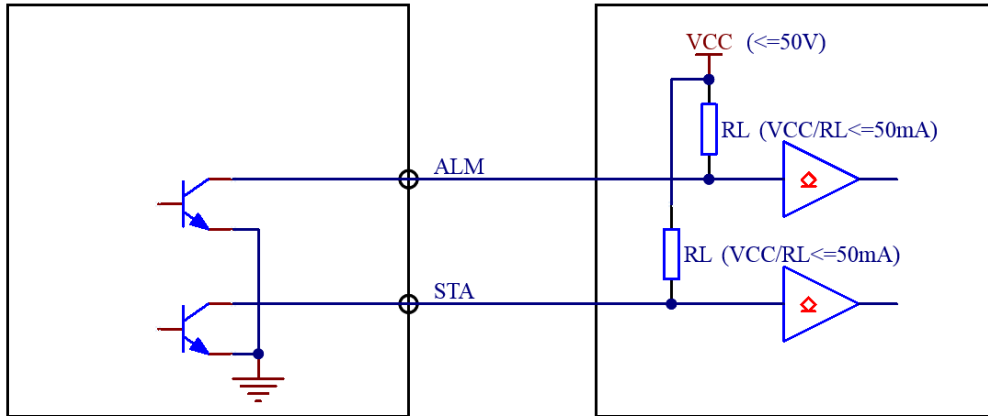

FIG. 5 Output Signal Wiring Diagram

3.3. Control signal timing diagram

To ensure the normal operation of the product, PU, DR, and MF should meet the following timing requirements.

As shown in the following figure:

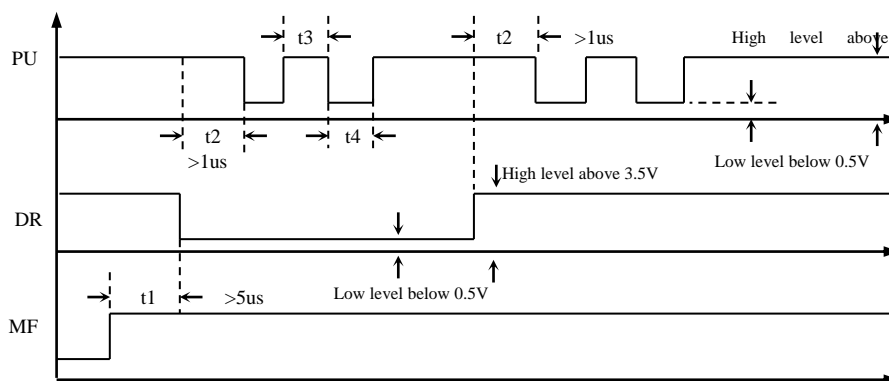

FIG. 6 Control signal timing diagram

Note:

- 1) t1: MF (enable signal) should be at least 5μs ahead of DR signal is determined to be high. Under normal circumstances, it can be suspended in the air;
- 2) t2: DR at least advances PU descent edge by 1μs Determine whether its state is high or low;

- 3) t3: The pulse width should not be less than 1.5us.
- 4) t4: Low level width not less than 1.5us.

3.4. Dip switch Settings

The iST57-FD uses a 6-bit DIP switch to set the phase current and subdivision. The detailed description is as follows:

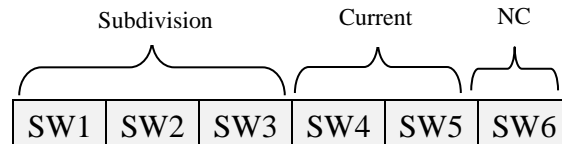

FIG. 7 Dialing Diagram

Dialing SW1, SW2, and SW3 is used to set the electronic subdivision score, as shown in the breakdown table below:

| Pulse/rev | SW1 | SW2 | SW3 |
|-----------|-----|-----|-----|
| 400 | ON | ON | ON |
| 800 | OFF | ON | ON |
| 1600 | ON | OFF | ON |
| 3200 | OFF | OFF | ON |
| 6400 | ON | ON | OFF |
| 12800 | OFF | ON | OFF |
| 25600 | ON | OFF | OFF |
| 51200 | OFF | OFF | OFF |

Dialing SW4 and SW5 is used to set the operating current of the motor, as shown in the ammeter below:



| Current(RMS) | SW4 | SW5 |
|--------------|-----|-----|
| 2.0A | ON | ON |
| 3.0A | OFF | ON |
| 4.0A | ON | OFF |
| 5.0A | OFF | OFF |

3.5. LED Status Indication

The green LED is the power indicator light. When the motor is powered on, the

green LED remains on; Cut off the power and the green LED will turn off.

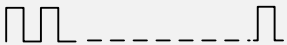
The red LED is the fault indicator light. When a fault occurs, the red indicator light flashes for a period of 600ms (Duty 50%). After flashing, the light goes off for 1 second and cycles back and forth; When the fault is cleared by the user, the red LED remains off. The number of red LED flashes represents different fault information, as shown in the table below.

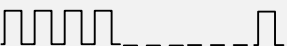
| Serial Number | Flashing Times | Red Indicator Flashing Waveform | Fault Description |
|---------------|----------------|---|------------------------|
| 1 | 1 |  | Overcurrent fault |
| 2 | 2 |  | Overvoltage fault |
| 3 | 3 |  | Undervoltage fault |
| 4 | 4 |  | Over temperature fault |

3.6. Wiring requirements

1) To prevent interference with the driver, it is recommended to use shielded cables for the control signal, and the shielding layer should be short circuited to PE (protective ground). Unless otherwise specified, the shielding wire of the control signal cable should be grounded at one end: the upper computer end of the shielding wire should be grounded, and the driver end of the shielding wire should be suspended. Grounding is only allowed at the same point within the same machine. If it is not a true grounding wire, it may cause serious interference, and the shielding layer is not connected at this time.

2) Pulse and direction signal lines are not allowed to be tied side by side with motor lines. It is best to separate them at least 10cm or more, otherwise motor noise can easily interfere with pulse direction signals, causing motor positioning errors, system instability, and other faults.

3) If a power supply supplies multiple drives, parallel connection should be



adopted at the power supply, and chain connection from one to another is not allowed.

4) It is strictly prohibited to plug and unplug the driver terminals with electricity. When a live motor stops, there is still a large current flowing through the coil, and plugging and unplugging the terminals will cause a huge instantaneous induced electric potential that will burn out the driver.

5) It is strictly prohibited to solder the wire head and connect it to the wiring terminal, otherwise it may overheat and damage the terminal due to increased contact resistance.

6) The wiring terminal should not be exposed outside the terminal to prevent accidental short circuit and damage to the driver.

4. Common problems and solutions

For other common problems and solutions, refer to the table below.

| Phenomenon | Possible issues | Solution measures |
|---------------------------|--------------------------|--|
| The motor does not rotate | Motor shaft has torque | Weak pulse signal, check the resistance value of the current limiting resistor |
| | There is an alarm signal | Check if the heat dissipation and power supply voltage are normal |
| | No alarm, no torque | Check if the enable signal is valid |
| Motor stuck or lost step | Insufficient torque | Increase the current setting by dialing the code |
| | Low voltage | Appropriately increase the voltage |
| | Acceleration too fast | Extend pulse acceleration time |

5. Product warranty clause of FULLING MOTOR

1) One year warranty

FULLING provides a one-year warranty against defects in the raw materials and workmanship of its products from the date of shipment. During the warranty period, FULLING provides free repair service for defective products.

2) Not covered by warranty



- A、 Inappropriate wiring, such as reversed polarity of the power supply and live plugging and unplugging
- B、 Unauthorized modification of internal components
- C、 Use beyond electrical and environmental requirements
- D、 Poor environmental heat dissipation

3) Repair process

If the product needs to be repaired, the following process will be followed:

(1) Before shipping, please call the customer service personnel of FULLING to obtain a repair permit number;

(2) Please send a written explanation along with the goods, explaining the phenomenon of the faulty drive being repaired; The voltage, current, and usage environment at the time of the malfunction; The name, phone number, and mailing address of the contact person.

(3) Prepaid postage to CHANGZHOU FULLING MOTOR Co., Ltd., No. 69 Kunlun Road, Xinbei District, Changzhou City, Jiangsu Province
Postal code: 213032.

4) Warranty Limitations

A、 The warranty scope of FULLING's products is limited to the components and processes of the products (i.e. consistency)

B、 FULLING does not guarantee that its products will be suitable for the specific use of customers, as the suitability is also related to the technical specifications, usage conditions, and environment of the use.

5) Maintenance requirements

When repairing, please truthfully fill out the "Repair Report" (this form can be downloaded from www.fullingmotor.com) for maintenance analysis. Mailing address: CHANGZHOU FULLING MOTOR Co., Ltd., No. 69 Kunlun Road, Xinbei District, Changzhou City, Jiangsu Province. Postal code: 213032.



CHANGZHOU FULLING MOTOR CO., LTD

Address: No. 69 Kunlun Road, Xinbei District, Changzhou City, Jiangsu Province

Postal Code: 213032

Phone:+86-519-85132957

Fax:+86-519-85132956

Email: info@fullingmotor.com

